

THIS DRAWING IS UNPUBLISHED. RELEASED FOR PUBLICATION
 © COPYRIGHT BY TYCO ELECTRONICS CORPORATION. ALL INTERNATIONAL RIGHTS RESERVED.

LOC	DIST	REVISIONS			
P	LTR	DESCRIPTION	DATE	DWN	APVD
G	14	P3	REVISED PER ECR-08-022232	06OCT08	HMR TM

AMP
WIRE RANGE

12-10 AWG
SOLID OR STRANDED

- 1 STAMP AMP 12-10* APPROX AS SHOWN
- 2 MAXIMUM LENGTH DOES NOT INCLUDE MANUFACTURING TABS
- 3 IN PLATE .00254[.000100] MIN THK PER MIL-T-10727
- 4 BLACK OXIDE PER MIL-F-495
- 5 UL LISTED E13288, 12-10 AWG STRANDED.
- 6 MATERIAL; COPPER PER ASTM B-152 ANNEALED
- 7 FINISH: TIN/LEAD (60/40) PLATE, .000100 MIN THK PER SAE-AMS-P-81728
- 8 CSA CERTIFIED LR7189, 12-10 AWG SOLID OR STRANDED
- 9 PRELIMINARY - NOT FOR PRODUCTION

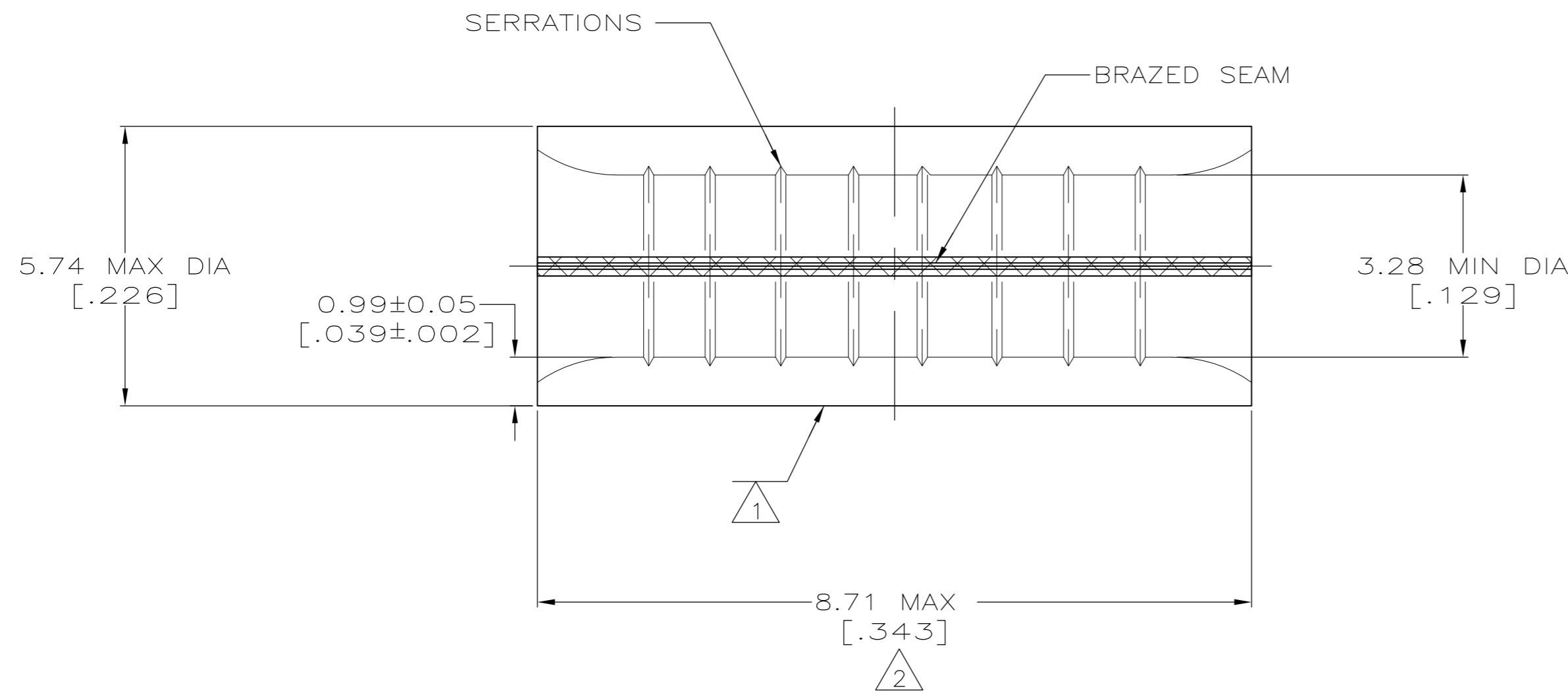

APPROVALS	FINISH	QTY	PACKAGE TYPE	PART NO
5 8	3	10	LOOSE PIECE, BAG	8-34138-3
5 8	3	50	LOOSE PIECE, BOX	8-34138-2
---	7	---	LOOSE PIECE	34138-3
---	4	---	LOOSE PIECE	34138-1
5 8	3	---	LOOSE PIECE	34138

AMP INCORPORATED CUSTOMER SERVICE SYSTEMS		MAX RECOMMENDED OPERATING TEMPERATURE: 170° C
FOR ADDITIONAL PRODUCT INFORMATION OR COPIES OF DRAWINGS AND TECHNICAL DOCUMENTS	PRODUCT INFORMATION CENTER 1-800-522-6752	VOLTAGE RATING: N/A
FOR APPLICATION TOOLING INFORMATION	TOOLING ASSISTANCE CENTER 1-800-722-1111	CIRCULAR MIL AREA: 2.62-6.64mm² [5,180-13,100] STRANDED
FOR ORDER ENTRY	1-800-526-5142	THIS DRAWING IS A CONTROLLED DOCUMENT FOR AMP INCORPORATED. IT IS SUBJECT TO CHANGE AND THE CONTROLLING ENGINEERING ORGANIZATION SHOULD BE CONTACTED FOR THE LATEST REVISION.

THIS DRAWING IS A CONTROLLED DOCUMENT.		DWN TA BRINKMAN 4-14-93	Tyco Electronics Corporation Harrisburg, PA 17105-3608	
DIMENSIONS: INCHES		CHK DA PATTERSON 4-14-93	NAME SPLICE, PARALLEL, SOLISTRAND	
TOLERANCES UNLESS OTHERWISE SPECIFIED: 0 PLC ± - 1 PLC ± - 2 PLC ± - 3 PLC ± - 4 PLC ± - ANGLES ± -		APVD DA PATTERSON 4-14-93	SIZE A2	
MATERIAL 6		FINISH SEE NOTES	CAGE CODE 00779	DRAWING NO 34138
		WEIGHT -	RESTRICTED TO -	SCALE 10:1
		CUSTOMER DRAWING	SHEET 1 of 1	REV P3